

MS5900 Users Manual

Table of Contents

Introduction

Motor and Phase Rotation Indicator is a handheld, battery-operated instrument designed to detect the rotary field of three-phase systems and determine motor-rotation direction.

Accessories

Motor and Phase Rotation Indicator ships with the following items:

- 3 test leads
- 3 test probes
- 3 alligator clips
- 9 V battery
- Users Manual

If any of these items are damaged or missing, contact the place of purchase immediately.

Identifies conditions and actions that may damage the apparatus.

Identifies conditions and actions that pose hazard(s) to the user.



Safety Information

To prevent electric shock or fire, do the following:

Read the safety information carefully before using or servicing the instrument.









- Adhere to local and national safety codes.
- Individual protective equipment must be used to prevent shock and injury
- Use of instrument in a manner not specified by the manufacturer may impair safety features/protection provided by the equipment.
- Avoid working alone.
- Inspect the test leads for damaged insulation or exposed metal. Check test lead continuity. Damaged leads must be replaced. Do not use the apparatus if it looks damaged.
- Be careful when working above 30 V ac rms, 42 V ac peak and 60 V dc. Such voltages pose a shock hazard.
- When using the probes, keep fingers away from probe contacts. Keep fingers behind the finger guards on the probes.
- Measurements can be adversely affected by impedances of additional operating circuits connected in parallel or by transient currents.
- Verify operation on a known source prior to measuring hazardous voltages (voltages above 30 V ac rms, 42 V ac peak and 60 V dc).
- Do not use the apparatus with any of the parts removed.
- Do not use the apparatus around explosive gas, vapor, or dust.
- Disconnect the test leads from power sources and the apparatus before changing the battery.

- Do not use the apparatus in a wet environment.

Symbols

The following symbols appear on the Motor and Phase Rotation Indicator or in this manual.

Table 1. Symbols

	Attention!
	Dangerous Voltage!
	Ground
	AC
	DC
	Low Battery
	Fuse
	European union directives
	Double insulation

Elements of the apparatus

Indicators, buttons, and jacks are shown in Figure 1.

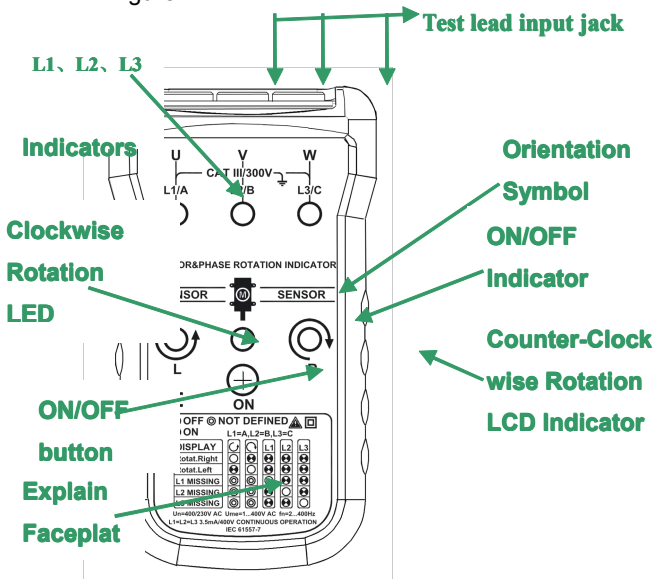

Figure 1.

Using the Motor & Phase Rotation Indicator

Determine Rotary Field Direction

To determine the rotary field direction:

1. Connect one end of the test leads to the apparatus. Make sure the L1, L2, and L3 test leads are connected to the corresponding input jacks.
2. Connect the test probes to the other end of the test leads.
3. Connect the test probes to the three mains phases. Press the ON/OFF button. The green ON indicator shows that the instrument is ready for testing.

Either the Clockwise or Counter Clockwise Rotary indicator illuminates showing the



on present.

ig

even if the neutral conductor, N, is connected instead of L1, L2, or L3. Refer to the face of the apparatus) for more information.

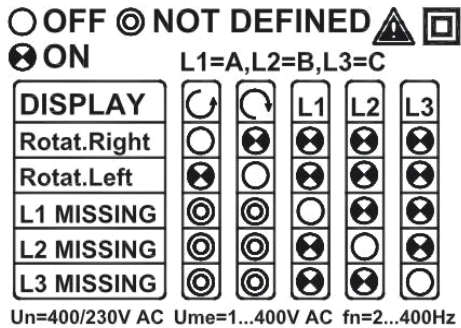

Figure 2. Phase Indication Table (shown on the face of the apparatus)

Non-Contact Rotary Field Indication

For non-contact rotary field indication:

1. Disconnect all test leads from the apparatus
2. Position the Indicator on the motor so that it is parallel to the length of the motor shaft. The Indicator should be one inch or closer to the motor. See Figure 3.
3. Press the ON/OFF button. The green ON indicator shows that the instrument is ready for testing.

Either the Clockwise or Counter Clockwise Rotary indicator illuminates showing the type of rotary field direction present.

Note

The Indicator will not operate with engines controlled by frequency converters. The bottom of the apparatus should be oriented towards the drive shaft. See the OrientationSymbol on the apparatus.



圖 3. 馬達旋轉

Figure 3. Motor Rotation

See Table 2 for the minimum motor diameter and number of pole pair to obtain a reliable

test result.

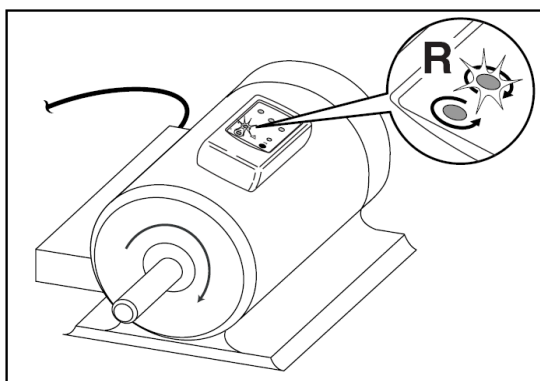
Table 2. Reliable Motor Test Requirements

Number of Pole Pair	Rotary Number of Rotary Field (1/min) at Frequency (Hz)			Angle Between Poles °	Min. Ø of Motorcase cm
	16 2/3	50	60		
1	1000	3000	3600	60	5.3
2	500	1500	1800	30	10.7
3	333	1000	1200	20	16.0
4	250	750	900	15	21.4
5	200	600	720	12	26.7
6	167	500	600	10	32.1
8	125	375	450	7.5	42.8
10	100	300	360	6	53.5
12	83	250	300	5	64.2
16	62	188	225	3.75	85.6

Determine the Motor Connection

1. Connect one end of the test leads to the apparatus. Make sure the L1, L2, and L3 test leads are connected to the corresponding jack.
2. Connect the alligator clamps to the other end of the test leads.
3. Connect the alligator clamps to the motor connections, L1 to U, L2 to V, L3 to W.
4. Press the ON/OFF button. The green ON indicator shows that the instrument is ready for testing.
5. Turn the motor shaft half a revolution towards the right.

Note

The bottom of the apparatus should be oriented towards the drive shaft. See the Orientation Symbol on the apparatus.

Either the Clockwise or Counter Clockwise Rotary indicator illuminates showing the type of rotary field direction present.

Magnetic Field Detection

To detect a magnetic field, place the apparatus to a solenoid valve. A magnetic field is present if either the Counter Clockwise Rotary indicator illuminates.

Apparatus

See basic maintenance information.



Do not touch the apparatus:

Do not repair or service the apparatus unless qualified to do so.

- Make sure that the relevant calibration, performance test, and service information is being used.

Clean the apparatus with a damp cloth and mild detergent. Clean only with soap and water. No residue afterwards.



Do not touch the apparatus:

Do not use flammable or toxic solvents. Abrasives or solvents will damage the apparatus case.

Remove test leads from the apparatus.

Charging of the Batteries



Before charging, disconnect the test leads from the source before opening the apparatus for

battery replacement.

Note

The apparatus contains alkaline batteries. Do not dispose of these batteries with other solid waste. Used batteries should be disposed of by a qualified recycler or hazardous materials handler.

The apparatus uses a 9 V battery (supplied). To replace the battery, follow these steps and refer to Figure 4:

1. Disconnect test leads from any power source.
2. Remove the holster.
3. Place the apparatus face down on a nonabrasive surface and loosen the battery-door screw with a flat-blade screwdriver.
4. Lift the battery access lid away from the apparatus.
5. Replace the battery as shown in Figure 4. Observe the battery polarity shown in the battery compartment.
6. Secure the battery access lid back in position with the screw.
7. Place the apparatus back in the holster.

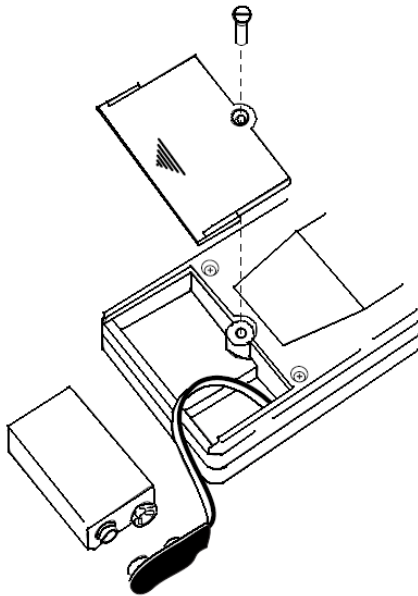

Figure 4. Battery Replacement

Specifications

Environmental

Operating Temperature

0 °C to +40 °C

Operating Altitude

2000 m

Pollution Degree

2

Type of Protection

IP 40

Mechanical Specifications

Size

124 x 61 x 27 mm (4.9 x 2.4 x 1.1 in)

Weight

150 g (0.3 lbs)

Humidity

15 % to 80 %

Safety Specifications

Electrical Safety

Meets DIN VDE 0411, IEC 61010 DIN,
VDE 0413-7, EN 61557-7, IEC 61557-7

Maximum Operating Voltage (U_{me})

400 V AC for all ranges

Protection Level

CAT III, 300 V

Electrical Specifications

Battery

6F22/9V

Current Consumption

max 20 mA

Battery Life

minimum 1 year for average use

Determine Rotary Field Direction

Nominal Voltage Rotary Direction

1 to 400 V AC

Nominal Voltage Phase Indication

120 to 400 V AC

Frequency Range (fn)

2 to 400 Hz

Test Currents (I_n per phase)

less than 3.5 mA

Non-Contact Rotary Field Indication

Frequency Range (fn)

2 to 400 Hz

Determine the Motor Connection

Nominal Test Voltage (U_{me})

1 to 400 V AC

Nominal Test Currents (I_n per phase)

less than 3.5 mA

Frequency Range (fn)

2 to 400 Hz